

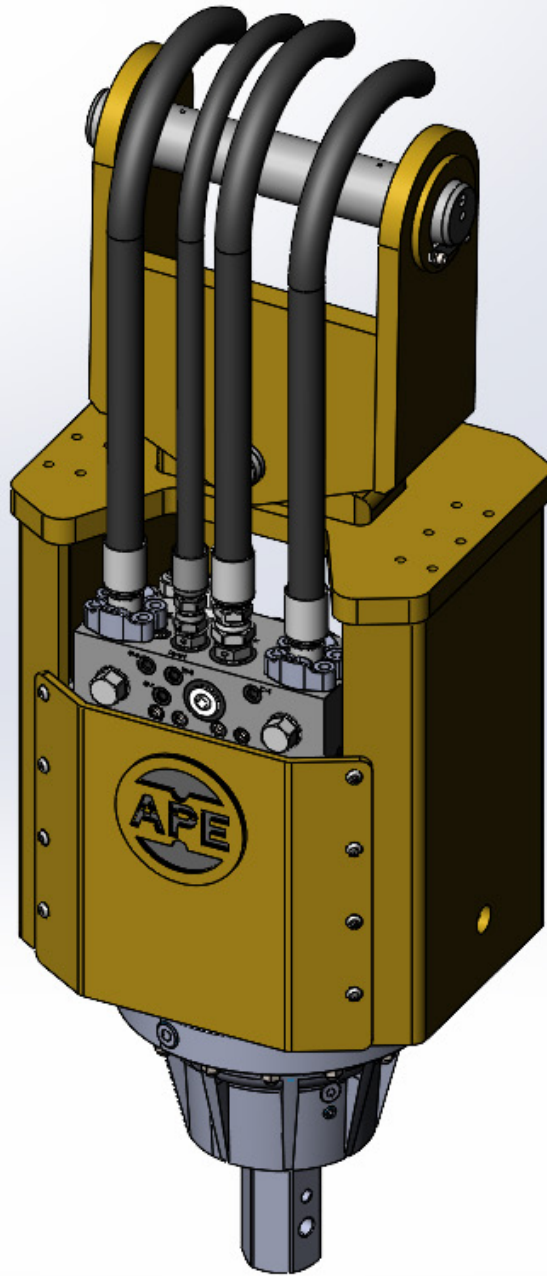

APE DANGLE DRILL OWNER'S MANUAL

DEEP FOUNDATION SOLUTIONS



800-248-8498

WWW.AMERICANPILEDRIVING.COM

MODEL 12K/20K Dangle Drill

Copyright © 2023 American Piledriving Equipment Inc. All Rights Reserved

Copyright © 2023 American Piledriving Equipment Inc.

*All rights reserved, No part of this publication may be reproduced, distributed, or transmitted in any form of by any means, including photocopying, recording, or other electronic or mechanical methods, without prior written permission of the publisher. For permission requests, write to the publisher, addressed “**Attention: American Piledriving Equipment Manual Division**” at the address below.*

AMERICAN PILEDIVING EQUIPMENT, INC.

7032 S. 196th Street

Kent, Washington 98032

Office: 253-872-0141

Toll Free: 800-248-8498

Fax: 253-872-8710

APE_Manuals@americanpiledriving.com



800-248-8498

WWW.AMERICANPIEDIVING.COM

MODEL 12K/20K DANGLE DRILL

Copyright © 2023 American Piledriving Equipment Inc. All Rights Reserved

QUICK REFERENCE GUIDE

This Quick Reference Guide will assist you in finding the information you're looking for.

GENERAL INFORMATION

MAINTENANCE

TROUBLE SHOOTING

REPLACEMENT PARTS

REFERENCE / NOTES

A Table of Contents is included after the Foreword.

Description:

MODEL 12K/20K DANGLE DRILL



800-248-8498

WWW.AMERICANPILEDIVING.COM

MODEL 12K/20K DANGLE DRILL

Copyright © 2023 American Piledriving Equipment Inc. All Rights Reserved

WARRANTY INFORMATION

American Piledriving Equipment, Inc. (APE) warrants new products sold by it to be free from defects in material or workmanship for a period of one (1) years after the date of delivery to the first user and subject to the following conditions:

- APE's obligation and liability under this WARRANTY is expressly limited to repairing or replacing, at APE's option, any parts which appear to APE upon inspection to have been defective in material or workmanship. Such parts shall be provided at no cost to the user, at the business establishment of APE or the authorized APE distributor of the product during regular working hours.
- This WARRANTY shall not apply to component parts or accessories of products not manufactured by APE, and which carry the warranty of the manufacturer thereof, or to normal maintenance (such as engine tune-up) or normal maintenance parts (such as filters).
- Replacement or repair parts installed in the product covered by this WARRANTY are warranted only for the remainder of the warranty as if such parts were original components of said product.
- APE makes no other warranty, expressed or implied, and makes no warranty of merchantability of fitness for any particular purpose.
- APE's obligations under this WARRANTY shall not include any transportation charges, costs of installation, duty, taxes or any other charges whatsoever, or any liability for direct, indirect, incidental or consequential damage or delay.
- If requested by APE, products or parts for which a warranty claim is made are to be returned, transportation prepaid, to APE.

OIL MUST MEET ISO CLEANLINESS CODE 17/15/11. OIL THAT DOES NOT MEET CLEANLINESS CODE WILL **VOID** THE WARRANTY

ANY IMPROPER USE, INCLUDING OPERATION AFTER DISCOVERY OF DEFECTIVE OR WORN PARTS, OPERATION BEYOND RATED CAPACITY, SUBSTITUTION OF ANY PARTS WHATSOEVER, USE OF PARTS NOT APPROVED BY APE OR ANY ALTERATION OR REPAIR BY OTHERS IN SUCH A MANNER AS, IN APE'S JUDGMENT, AFFECTS THE PRODUCT MATERIALLY AND ADVERSELY, SHALL **VOID** THIS WARRANTY.

ANY TYPE OF WELDING ON APE'S EQUIPMENT WILL **VOID** THE WARRANTY UNLESS AUTHORIZED IN WRITING BY APE

NO EMPLOYEE IS AUTHORIZED TO CHANGE THIS WARRANTY IN ANY WAY OR GRANT ANY OTHER WARRANTY UNLESS SUCH CHANGE IS MADE IN WRITING AND SIGNED BY AN OFFICER OF APE, INC.

FOREWORD

This manual covers **APE Dangle Drill** safety, operation instructions, lubrication and maintenance information. This manual should be stored in or near the engine area in a literature holder or literature storage area.

The data provided in this manual gives the necessary information to operate and maintain APE equipment. The listed procedures are to be performed by qualified personnel who have an understanding of the equipment and who follow all safety precautions.

Some photographs or illustrations in this manual show details or attachments that may be different from your equipment. Continuing improvement and advancement of product design may have caused changes to your equipment which are not included in this manual. Whenever a question arises regarding your equipment, or this manual, please consult with your APE dealer for the latest available information.

Using this manual:

- Refer to the Table of Contents for the page location of applicable sections.
- All weights and measurements are in English and Metric units.
- Please visit www.americanpiledriving.com for product data sheets and manuals and latest available information.

DISCLAIMER:

This unit was tested and flushed before leaving our facility. In order to help provide years of trouble-free usage, please review the following documentation and make sure to clean and flush the quick disconnect fitting on any equipment before connecting it to the power unit.

Refer to schematic diagrams and the BOM (Bill of Materials) for component part specifications and recommended spare parts.

When calling APE, always have the equipment serial number on hand in order to obtain quicker service.

IDENTIFICATION TAG



Serial No. can be found here.

CALIFORNIA

Proposition 65 Warning

Diesel engine exhaust and some of its constituents are known to the State of California to cause cancer, birth defects, and other reproductive harm.

CALIFORNIA

Proposition 65 Warning

Battery posts, terminals and related accessories contain lead and lead compounds, chemicals known to the state of California to cause cancer, birth defects and reproductive harm. Wash hands after handling.



TABLE OF CONTENTS

WARRANTY INFORMATION	4
FOREWORD	5
TABLE OF CONTENTS	6
SPECIFICATIONS.....	7
Model 12K Specifications	7
Model 20K Specifications	7
SAFETY SECTION	8
General Safety Precautions	8
Safety Messages	10
General Hazard Information.....	11
OPERATION SECTION.....	13
Lifting the Dangle Drill.....	13
Connecting the Hydraulics.....	14
Commissioning Procedure.....	15
Flushing the Hydraulic System.....	15
Break-In Period	16
Operating Temperatures	16
DAILY CHECKLIST.....	17
MAINTENANCE AND STORAGE.....	18
Maintenance Chart.....	18
Understanding the Hydraulic System	18
Preventative Maintenance	19
Storage	19
TROUBLESHOOTING	20
Hydraulic Schematic	20
Bale Dimensions	21
REPLACEMENT PARTS.....	22
Drill Assembly.....	22
Dangle Drill Manifold.....	24
Dangle Drill Accessories	26
REFERENCE / NOTES.....	28
Understanding ISO Codes.....	28
Target ISO Cleanliness Codes.....	29
Recommended Bolt Tightening Torque	30



SPECIFICATIONS

Model 12K Specifications

DIMENSIONS

Overall Depth	16.28 in	(414 mm)
Overall Width	20 in	(49 cm)
Overall Height	59 in	(149 cm)
Suspended Weight	1,060 lbs	(481 kg)
Output Shaft ID	3" HEX	

PERFORMANCE

Max Pressure	4,500 PSI	(310 Bar)
Max Torque	12,000 Ft-Lbs	(1659 kg-m)
Rotation Speed	35 RPM	
Max Flow GPM (LPM)	30 GPM	(114 LPM)
Max Horse Power (kW)	80 HP	(60 kW)

Model 20K Specifications

DIMENSIONS

Overall Depth	16.28 in	(414 mm)
Overall Width	20 in	(49 cm)
Overall Height	59 in	(149 cm)
Suspended Weight	1,130 lbs	(513 kg)
Output Shaft ID	3" HEX	

PERFORMANCE

Max Pressure	4,100 PSI	(283 Bar)
Max Torque	20,000 Ft-Lbs	(2765 kg-m)
Rotation Speed	30 RPM	
Max Flow GPM (LPM)	46 GPM	(174 LPM)
Max Horse Power (kW)	110 HP	(82 kW)



SAFETY SECTION

General Safety Precautions



DANGER

DANGER indicates a hazardous situation which, if not avoided, will result in death or serious injury.



WARNING

WARNING indicates a hazardous situation which, if not avoided, could result in death or serious injury.



CAUTION

CAUTION indicates a hazardous situation where injury could occur but is unlikely to be serious or lead to death.

NOTICE

NOTICE indicates information that may help or guide you in the operation or service of the equipment.

DISCLAIMER:

This unit was tested and flushed before leaving our facility. In order to help provide years of trouble free usage, please review the following documentation and make sure to clean and flush the field piping before connecting it to the power unit.

Refer to schematic diagrams and the BOM (Bill of Materials) for component part specifications and recommended spare parts.

When calling APE (American Piledriving Equipment), always inform them of the supplied serial # in order to obtain quicker service

NOTICE

READ THIS MANUAL THOROUGHLY BEFORE OPERATING AND / OR WORKING ON THE EQUIPMENT

1. Read and follow any safety instructions in the CATERPILLAR ENGINE OPERATOR'S MANUAL.
2. Only well-trained and experienced personnel should attempt to operate or maintain this equipment.
3. NEVER adjust, lubricate and/or repair the unit when it is in operation or lifted above ground level.
4. NEVER remove, paint over and/or cover warning or safety labels. If labels become damaged or unreadable, replace immediately.
5. All personnel should wear approved safety clothing including HARD HATS, SAFETY SHOES, SAFETY GLASSES and HEARING PROTECTION when near this equipment.
6. Do **NOT** stand any closer to this equipment than necessary when it is in operation. Parts may loosen and fall. **NEVER** stand under operating or elevated equipment.
7. When maintaining and/or repairing the equipment, **NEVER** substitute parts not supplied or approved in writing by APE.

NOTICE

Do NOT weld or flame cut on this equipment.

8. NEVER use or store flammable liquids on or near the engine.
9. Insure that all lifting equipment, including cranes, wire rope, slings, hooks, shackles, etc., are properly sized for the worst caseloads anticipated during operations.
10. If there are any questions about the weights, specifications and/or performance of the unit, contact APE before handling and/or operating the equipment.
11. Check wire rope clips for tightness and wire ropes for wear daily.
12. Insure that ground vibrations will not damage or collapse adjacent structures or excavations.

SAFETY SECTION



When operating in an enclosed area, exhaust fumes should be piped outside. Continued breathing of exhaust fumes may prove FATAL.

13. Remove all tools, parts and/or electrical cords before starting the unit.
14. When servicing batteries, do **NOT** smoke and/or use an open flame in the vicinity. Batteries generate explosive gas during charging. There must be proper ventilation when charging batteries.
15. When filling the fuel tank, do **NOT** smoke and/or use an open flame in the vicinity.
16. If abnormal equipment operation is observed, discontinue use immediately and correct the problem.
17. Do **NOT** leave the equipment control pendant (radio control) unattended.
18. Store oily rags in approved containers and away from the engine exhaust system.
19. If running an auger/drill, make sure that the Auger rotation switch is in NEUTRAL before starting the Power Unit engine
20. Do **NOT** adjust and/or set the hydraulic pressures higher and/or lower than those specified in this Manual.
21. NEVER operate this equipment with hydraulic hoses that are damaged or 'kinked'. Replace damaged hoses immediately.
22. Do **NOT** lift and/or support hydraulic hoses with wire rope slings.
23. NEVER attempt to connect Quick Disconnects (QDs) when the Power Unit is running.
24. Do **NOT** pull on and/or attempt to move equipment with the hydraulic hoses.
25. Do **NOT** attempt to locate hydraulic leaks with your hands. High-pressure leaks can penetrate skin and cause severe damage, blood poisoning and/or infection.
26. Do **NOT** attempt to repair leaks while the equipment is in operation.
27. Do **NOT** attempt to tighten and/or loosen fittings and/or hoses when the machine is in operation.
28. Power Unit must always be placed on level, stable ground.

29. Do **NOT** remove Power Unit heat shields. Do NOT attempt to use the Power Unit without heat shields. Severe fires may result.

NOTICE

A properly maintained fire extinguisher, suitable for oil fires, MUST be kept in the immediate vicinity of equipment operations.

30. When moving and/or transporting this equipment, insure that the vehicle and/or vessel is of sufficient capacity to handle the load. Make sure that the equipment is properly tied down.
31. When moving and/or transporting this equipment, be sure that the QD Dust Caps are tight and that the cap safety cables are in place. Be sure that all equipment parts are tight and/or properly secured before shipment. Unsecured parts may vibrate loose and fall during transport causing injury and/or property damage.
32. Rounded and/or damaged bolt heads and/or nuts should be replaced so that proper torque values may be obtained. Proper torque values are necessary to prevent parts on this equipment, leads and/or crane booms from loosening and/or falling. (Refer to the torque chart in this manual for the proper values.)
33. When operating in a closed area, pipe exhaust fumes outside. (**Warning:** Breathing exhaust fumes can cause serious injury or even death.)
34. When loading or unloading the power unit using a forklift, the forks must be placed under the entire depth of the unit.
35. Keep hands away from rotating flighting auger shaft and/or rotary joint.
36. Do **NOT** allow clothing, hoses, ropes, etc., to be entangled in, or wrap around, rotating flighting, Auger Shaft and /or rotary joint.
37. Never stand under an equipment at any time and keep your eyes on the equipment when it is in operation.



SAFETY SECTION

SAFETY MESSAGES

There may be several specific safety messages on your equipment. The exact location and description of the safety messages are reviewed in this section. Become familiar with all safety messages.

Ensure that all the safety messages are legible. Clean the safety messages or replace the safety messages if the words cannot be read or if the illustrations are not visible. Use a cloth, water and soap to clean the safety messages. Do not use solvents, gasoline, or other harsh chemicals. Solvents, gasoline, or harsh chemicals could loosen the adhesive that secures the safety messages. The safety messages that are loosened could drop off the equipment.

Replace any safety message that is damaged or missing. If a safety message is attached to a part of the equipment that is replaced, install a new safety message on the replacement part. Your APE dealer can provide new safety messages.



Do not operate or work on this equipment unless you have read and understand the instructions and warnings in the Operation and Maintenance Manual. Failure to follow the instructions or read the warnings could result in injury or death. Contact any APE dealer for replacement manuals. Proper care is your responsibility.

QUICK DISCONNECT NOTICE

NOTICE: QUICK DIS-CONNECTS MUST BE FULLY SEATED TO ALLOW FREE HYDRAULIC FLOW. BLOCKED HYDRAULIC FLOW WILL STOP OR SLOW OPERATIONS AND CAUSE EXCESSIVE HEAT. TO SOLVE PROBLEM, REMOVE CLEAN AND RE INSTALL FITTINGS

Make sure all QD's are installed and connected completely. Failing to do so may cause damage or prevent proper operation.

IDENTIFICATION TAG



This information is important when contacting APE for replacement parts or other information.

- * Model
- * Serial No.

DO NOT WELD



Do **NOT** weld on or around the power unit unless authorized in writing by APE. Doing so will void all warranties and may cause damage to the power unit or vibro.

SAFETY GATE



Do not operate this equipment without a safety gate in place. Failing to use a safety gate may allow the pile to fall during driving.

SAFETY SECTION

GENERAL HAZARD INFORMATION



Attach a “Do Not Operate” warning tag to the start switch or controls before the equipment is serviced or repaired. Attach the warning tags to the engine and to each operator control panel. When appropriate disconnect the negative terminal on the battery.

Do not allow unauthorized personnel on the equipment or around the equipment while being serviced.

Cautiously remove the following parts. To help prevent spraying or splashing of pressurized fluids hold a rag over the part that is being removed.

- Filler caps
- Grease fittings
- Pressure taps
- Breathers
- Drain plugs

PRESSURIZED AIR AND WATER

Pressurized air and/or water can cause debris and/or hot water to be blown out which could result in personal injury.

The maximum air pressure for cleaning purposes must be reduced to 30psi (205 kPa) when the air nozzle is deadheaded and used with effective chip guarding (if applicable) and personal protective equipment. The maximum water pressure for cleaning purposes must be below 40psi (275 kPa). When pressurized air and/or pressurized water is used for cleaning, wear protective clothing, protective shoes, and eye protection. Eye

protection includes goggles or a protective face shield. Always wear eye protection for cleaning the cooling system.

Avoid direct spraying of water on electrical connectors, connections, and components. When using air for cleaning, allow the equipment to cool to reduce the possibility of fine debris igniting when redeposited on hot surfaces.

FLUID PENETRATION

Always use a board or cardboard when you check for a leak. Leaking fluid that is under pressure can penetrate body tissue. Fluid penetration can cause serious injury and possible death. A pin hole leak can cause severe injury. If fluid is injected into your skin, you must get medical treatment immediately. Seek treatment from a doctor that is familiar with this type of injury.

CONTAINING FLUID SPILLAGE

NOTICE

Care must be taken to ensure that fluids are contained during performance of inspection, maintenance, testing, adjusting, and repair of the equipment. Be prepared to collect the fluid with suitable containers before opening any compartment or disassembling any component containing fluids.

Dispose of all fluids according to local regulations and mandates.

SAFETY SECTION

LINES, TUBES, AND HOSES

Do not bend or strike high-pressure lines. Do not install lines, tubes, or hoses that are damaged.

Repair any fuel lines, oil lines, tubes, or hoses that are loose or damaged. Leaks can cause fires or injury.

Inspect all lines, tubes, and hoses carefully. Do not use bare hands to check for leaks. Always use a board or cardboard for checking equipment components for leaks. Tighten all connections to the recommended torque.

Check for the following conditions:

- End fittings that are damaged or leaking
- Outer covering that is chafed or cut
- Wire that is exposed in reinforced hose
- Outer covering that is ballooning locally
- Flexible part of the hose that is kinked or crushed
- Armoring that is embedded in the outer covering

Ensure that all of the clamps, guards, and heat shields are installed correctly. Correct installation of these components will help to prevent these effects: vibration, rubbing against other parts and excessive heat during operation.

INHALATION

Exhaust fumes can be hazardous to your health. If you operate the equipment in an enclosed area, adequate ventilation is necessary,

Burn Prevention

Do not touch any part of the equipment during operation. Allow the equipment to cool before any maintenance is performed on the engine. Relieve all pressures in the hydraulic system, fuel system, lubrication system, or cooling system before any lines, fittings, or related items are disconnected.

OIL

Hot oil and hot components can cause personal injury. Do not allow hot oil or hot components to contact the skin.

Keep all of the exhaust manifold and turbocharger heat shields in place in order to protect components from oil spray if there is a failure of a line, tube, or seal.

Crushing Prevention and Cutting Prevention

Support the equipment properly when work beneath the equipment is performed.

Unless other maintenance instructions are provided never attempt adjustments while the engine is running.

Stay clear of all rotating parts and moving parts. Leave the guards in place until maintenance is performed. After the maintenance is performed reinstall the guards.

Keep objects away from moving fan blades. The fan blades will throw objects or cut objects.

Wear protective glasses in order to avoid injury to the eyes.

Chips or other debris may fly off objects when objects are struck. Before objects are struck, ensure that no one will be injured by flying debris.

MOUNTING AND DISMOUNTING

Do not climb on the equipment, and do not jump off the equipment. Do not stand on the components which can not support your weight. Mount the equipment and dismount the equipment only at locations that have a ladder or handholds.

OPERATION SECTION

Lifting the Dangle Drill

The following instructions apply to all procedures associated with lifting the drill or drill motor. Read these instructions carefully and follow them closely.

- Use necessary Personal Protective Equipment (PPE) when working with the drill
- Support the drill properly, make sure that it cannot fall over or accidentally turn around.
- Use only appropriate equipment and attachments for lifting and positioning the drill.
- Always use the lifting equipment properly and check the load bearing capacities.
- Prevent unintended use of the drill during installation and maintenance procedures by preventing the pressurization of the hydraulic lines.
- The operating temperature of the motor may be over 140° F (60°C) which is hot enough to cause severe burns.

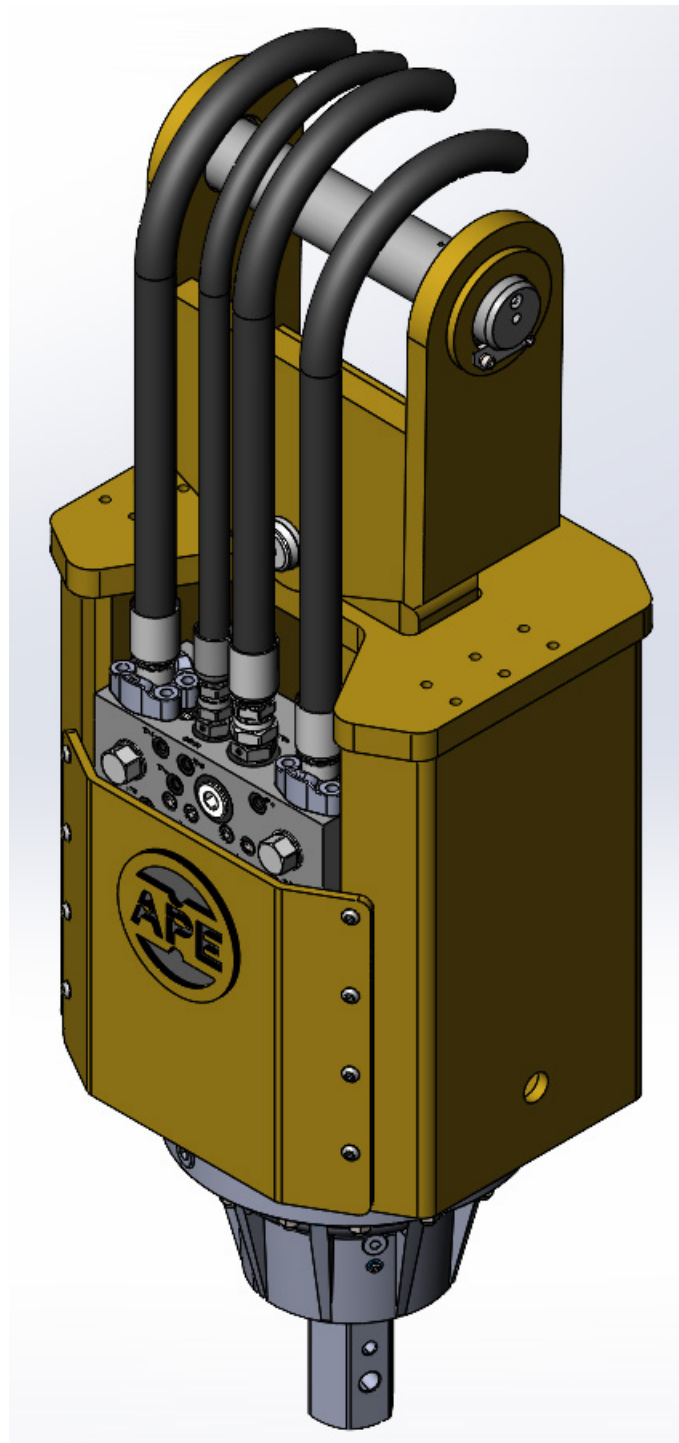

Connecting the Hydraulics

Connecting the hoses is one of the most critical aspects of commissioning an APE tool.

Take extreme care to keep these connections absolutely clean. This procedure is one of the most common ways for foreign particles to be introduced into a hydraulic system.

To connect the tool to the excavator:

1. Turn the excavator OFF.
2. Clean all quick disconnects with brake wash. They must be completely free of dirt or contaminants.
3. Attach quick disconnects. Note that quick disconnects of each hose type are mated to prevent backwards hookups.
4. Tighten all fittings to hand tightness. Verify with chain wrench.
 - DO NOT OVER TIGHTEN

New hydraulic fluid is NOT clean oil!

Oil must meet ISO cleanliness code 17/15/11



Beware of hot hydraulic fluid when disconnecting the hydraulic connections.



CAUTION

While filling the hydraulic lines, the driver motor shaft will rotate.

Please do the following:

- Set the engine at idle
- Run at idle for about 10 minutes to fill the lines
- Drive will not engage until the power unit is up to operating temperature.

Attention!

Pressurizing the system while there is air entrained in the fluid may cause damage to the components.

Let the system run at idle for an additional 10 minutes to allow the air to rise into the airspace of the hydraulic reservoir.



NOTICE: QUICK DIS-CONNECTS MUST BE FULLY SEATED TO ALLOW FREE HYDRAULIC FLOW. BLOCKED HYDRAULIC FLOW WILL STOP OR SLOW OPERATIONS AND CAUSE EXCESSIVE HEAT. TO SOLVE PROBLEM, REMOVE CLEAN AND RE INSTALL FITTINGS

Commissioning Procedure

Attention!

Do not run the drill at full power if the Flushing the Hydraulic System procedure has not been carried out.

Stressing an unused motor with full power may cause premature wear or failure.

Ensure that the following steps are met before starting a new or rebuilt dangle drill:

- The hydraulic circuit of the motor is flushed
 - The motor is installed appropriately
 - Flushing the Hydraulic System is carried out
 - The reservoir of the hydraulic system is full
- During the initial stages of starting a new or rebuilt dangle drill, please consider the following:
- Do **NOT** run the motor immediately with full power
 - Increase the load and speed of rotation gradually
 - Observe the motor and the hydraulic system for external leaks or abnormal noises during the commissioning procedure
 - Start the motor break-in period

Flushing the Hydraulic System

Prior to connecting the motor as part of the hydraulic system, the hydraulic circuit of the motor must always be flushed.

Flushing the hydraulic system should be performed after every service and/or repair.

The dangle drill is usually shipped with the driver motor hoses full of hydraulic oil and the unit may be used immediately.

If the drive hoses have been removed from the unit they will need to be filled before full speed operation.

1. The motor case needs to be filled by removing the top fill plug in port labeled "DRAIN" and pouring in new clean hydraulic oil. Port "TP-3" is another connection for the case drain hose.
2. With all hoses connected, run the excavator or power unit at low engine RPM and engage drive FWD. Continue to send the small amount of flow to the motor for 2 minutes. This will push the air that is present in the system through the hoses to bleed all the air out of the hoses and driver motor.
3. Switch the driver direction to REV and allow the driver to run for another 2 minutes.

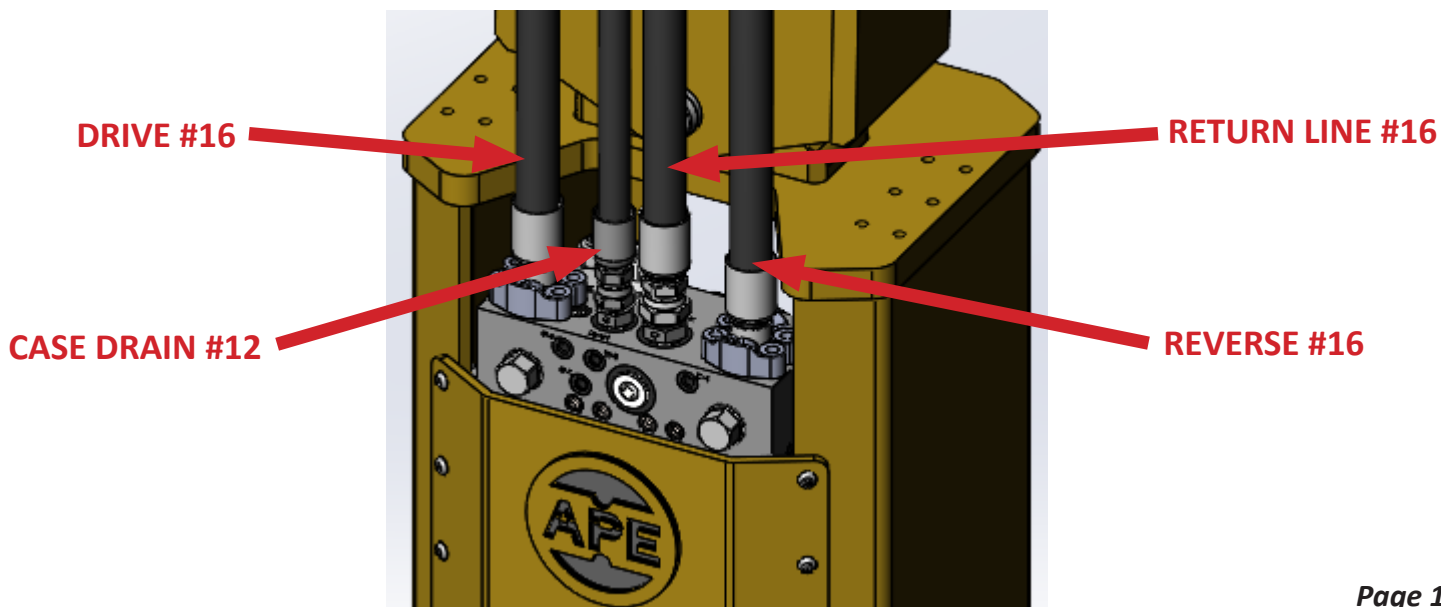

Break-In Period

New motors require a break in procedure.

The motor achieves its final properties during the first hours of use. All new and reconditioned motors should go through an initial break-in period.

Items to consider during this period:

- Break-in should last for, at least, **the first 8 hours of use.**
- The power output should remain under **50% of the maximum power capacity** of the motor.
- To limit the power output, constrain the working pressure, speed of rotation or both.
- The working pressure should be curbed so that pressure peaks which last over 2 seconds (2s) remain under 75% of the allowed pressure.



During this break-in period, the moving parts of the motor wear against each other. This means the wear of the parts sets to a stable state for the entire service life of the motor.

Operating Temperatures

The Operating Temperature references the internal temperature of the motor.

Take into consideration the following requirements:

- 70°C (158°F) – Avoid going over this Operating Temperature for improved service life
- 75°C (168°F) – Highest permissible intermittent Operating Temperature
- -35°C (-31°F) – Lowest permissible Operating Temperature

The Operating Temperature may be measured from the hydraulic fluid returning from the motor. Take into account the temperature of the hydraulic fluid returning from the case drain line.

DAILY CHECKLIST



Check the entire unit prior to and during set-up each day or at the beginning of each shift

Prior to starting the unit or at the beginning of each shift, check the following:

- Visually inspect all bolts, nuts and screws. This includes bolts fastening the bale pins.
- Visually inspect all hydraulic fittings for leaks. If a leak is found or suspected, shutdown the power unit. If a fitting appears to be damaged, replace with a new fitting.



It is absolutely imperative that no dirt or other impurities be permitted to contaminate the hydraulic fluid. Any contamination will drastically shorten the life of the high-pressure hydraulic system.



Vibration loosens bolts. Check them thoroughly.

MAINTENANCE AND STORAGE

Maintenance Chart

Daily	Weekly or 40 Hours	250 Hours or 6 Months	1500 Hours or 1 Year
<ul style="list-style-type: none"> Inspect for loose bolts and nuts Inspect for loose hoses and fittings Inspect grease ports Grease drill Visually inspect guide strips 	<ul style="list-style-type: none"> Grease drill Grease sheave Visually check all hoses for damage Check hose connections 	<ul style="list-style-type: none"> Change lubricating oil Change hydraulic filters Inspect/replaces hoses and clamps 	<ul style="list-style-type: none"> Replace hoses
<p>Follow the manufacturer's recommended maintenance procedures for the starter, alternator, batteries, electrical components, and fan clutch</p> <p>At each scheduled maintenance interval perform all previous checks which are due for scheduled maintenance.</p>			

MAINTENANCE

Understanding the Hydraulic System



It is imperative that the hydraulic fluid is kept clean to a minimum ISO Code 17/15/11

New hydraulic fluid is NOT clean oil

See attached document "Understanding ISO Codes" under the Reference / Notes Section

See Warranty document regarding fluid cleanliness at the beginning of this manual

Bulk oil does not typically meet the cleanliness standards required by APE equipment.

Preventative Maintenance

Preventative maintenance includes normal servicing that will keep the power unit in peak operative condition and prevent unnecessary trouble from developing. This servicing consists of periodic lubrication and inspection of moving parts and accessories of the unit.

Lubrication is an essential part of preventative maintenance controlling, to a great extent, the useful life of the unit. Different lubricants are needed and some components in the unit require more frequent lubrication than others. Therefore, it is important that the instructions regarding types of lubricants and frequency of their application be closely followed.

To prevent minor irregularities from developing into serious conditions that might involve shutdown and major repair, several other services or inspections are recommended for the same intervals as the periodic lubrications. The purpose of these services or inspections is to assure the uninterrupted operation of the unit.

- Thoroughly clean all lubrication fittings, caps, filler and level plugs along with their surrounding surfaces before servicing
- Prevent dirt from entering in with lubricants and coolants

The intervals given in the schedule are based upon normal operation.

Perform these services, inspections, etc., more often as needed for operation under abnormal or severe conditions.

Storage

During short-term storage of a power unit, the following should be taken into consideration:

- Cover any pressure openings and open threaded holes with suitable caps
- Protect the unpainted surfaces from dirt and moisture
- The power unit should not be stored in an area with substances that have an aggressive corrosive nature; i.e., solvents, acids, alkalies and/or salts

For long-term storage (over 9 months), the following additional actions are recommended:

- Damages to surface paint must be repaired before item is stored
- Protect the unpainted surfaces with suitable anti-corrosion treatment such as CRC SP-350, CorrosionX corrosion inhibitor, or WD-40 Long Term Corrosion Inhibitor
- Fill the power unit completely with hydraulic fluid



If these instructions are followed to the letter, the power unit may be stored for approximately 2-Years. However, as storage conditions do have a significant effect, all suggested time frames should be considered as guide values only.

TROUBLESHOOTING

Hydraulic Schematic

Notes:

- This manifold is common to the 12K and 20K Dangle Drills

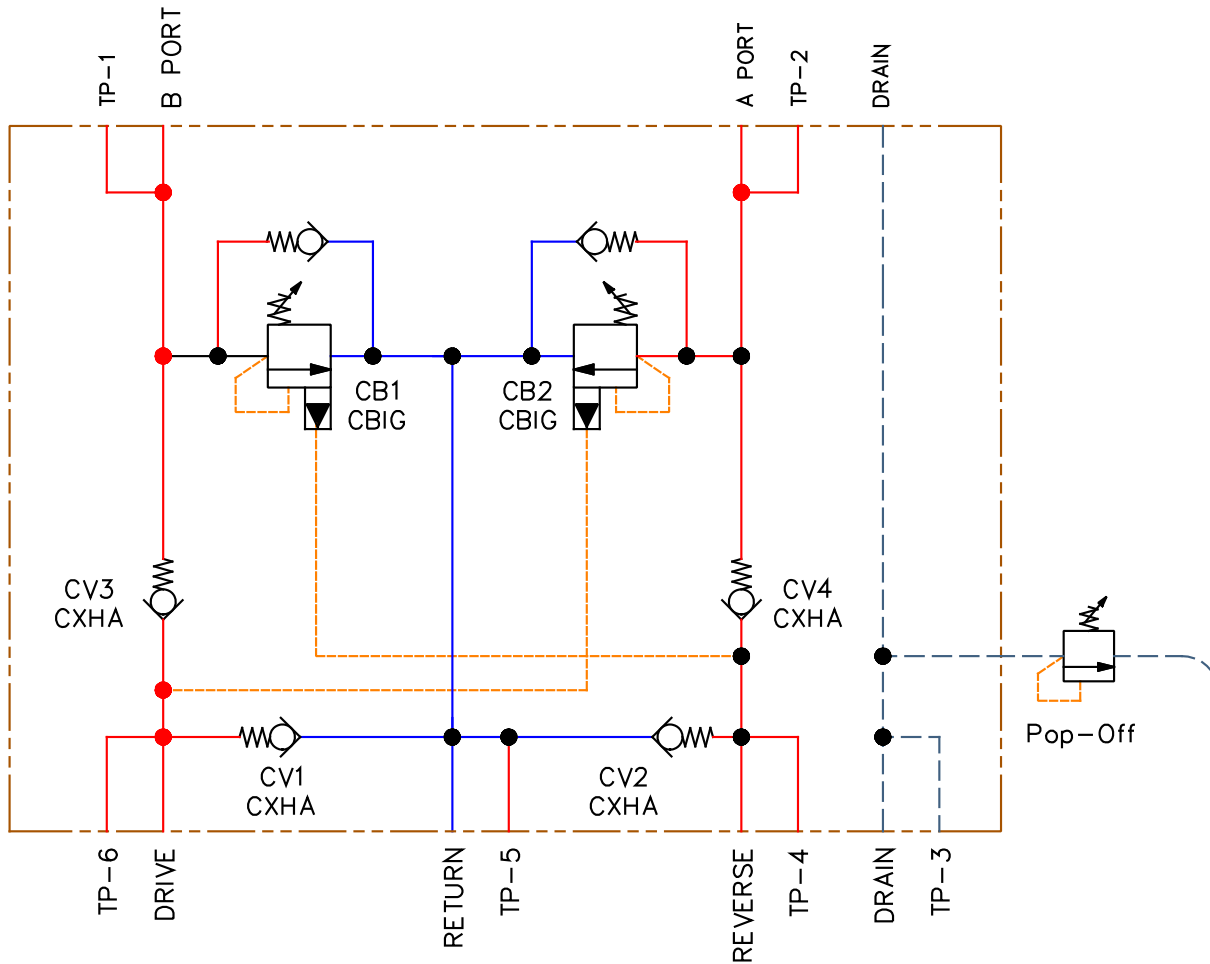

TROUBLE SHOOTING

Bale Dimensions

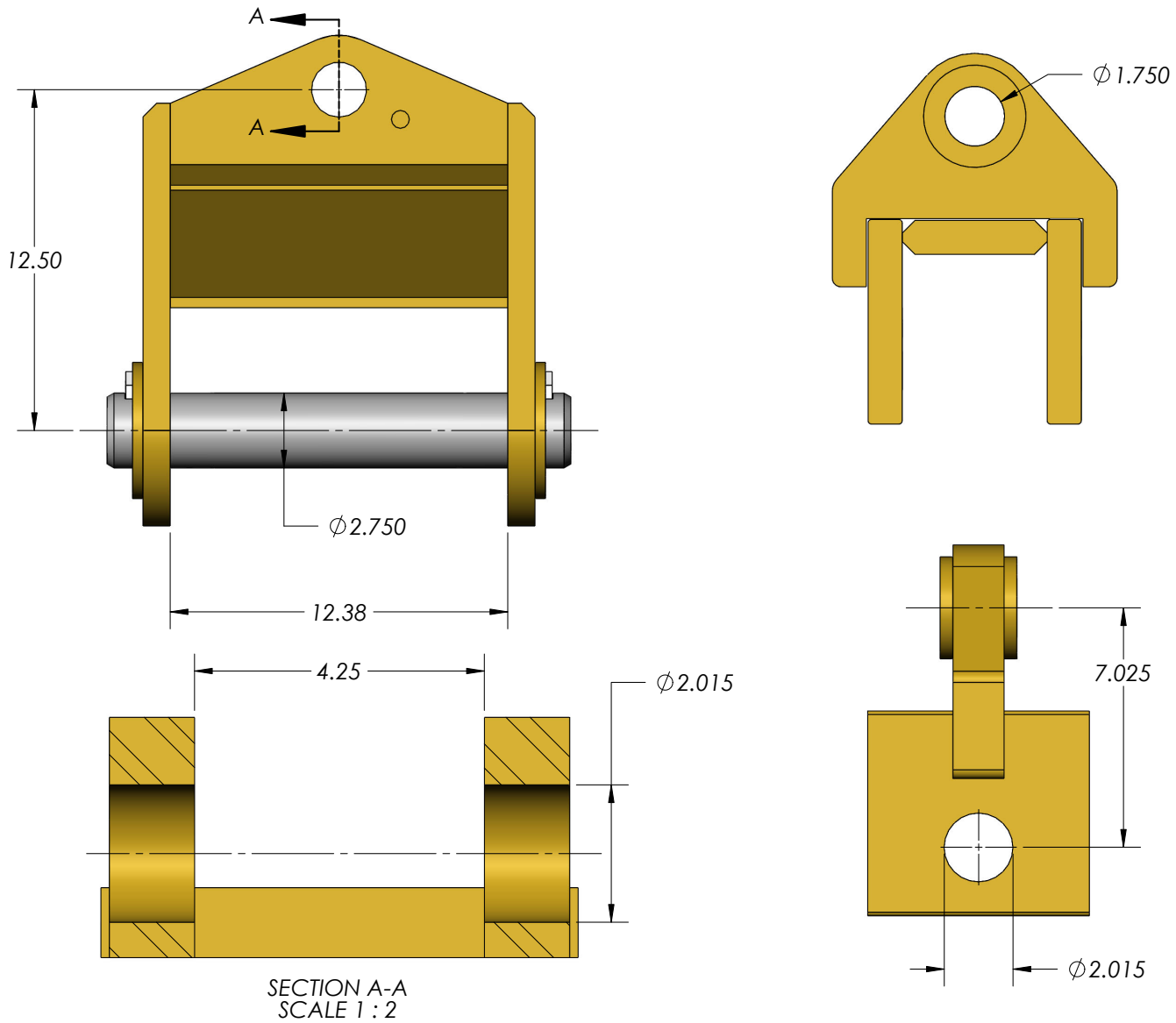

REPLACEMENT PARTS

Drill Assembly

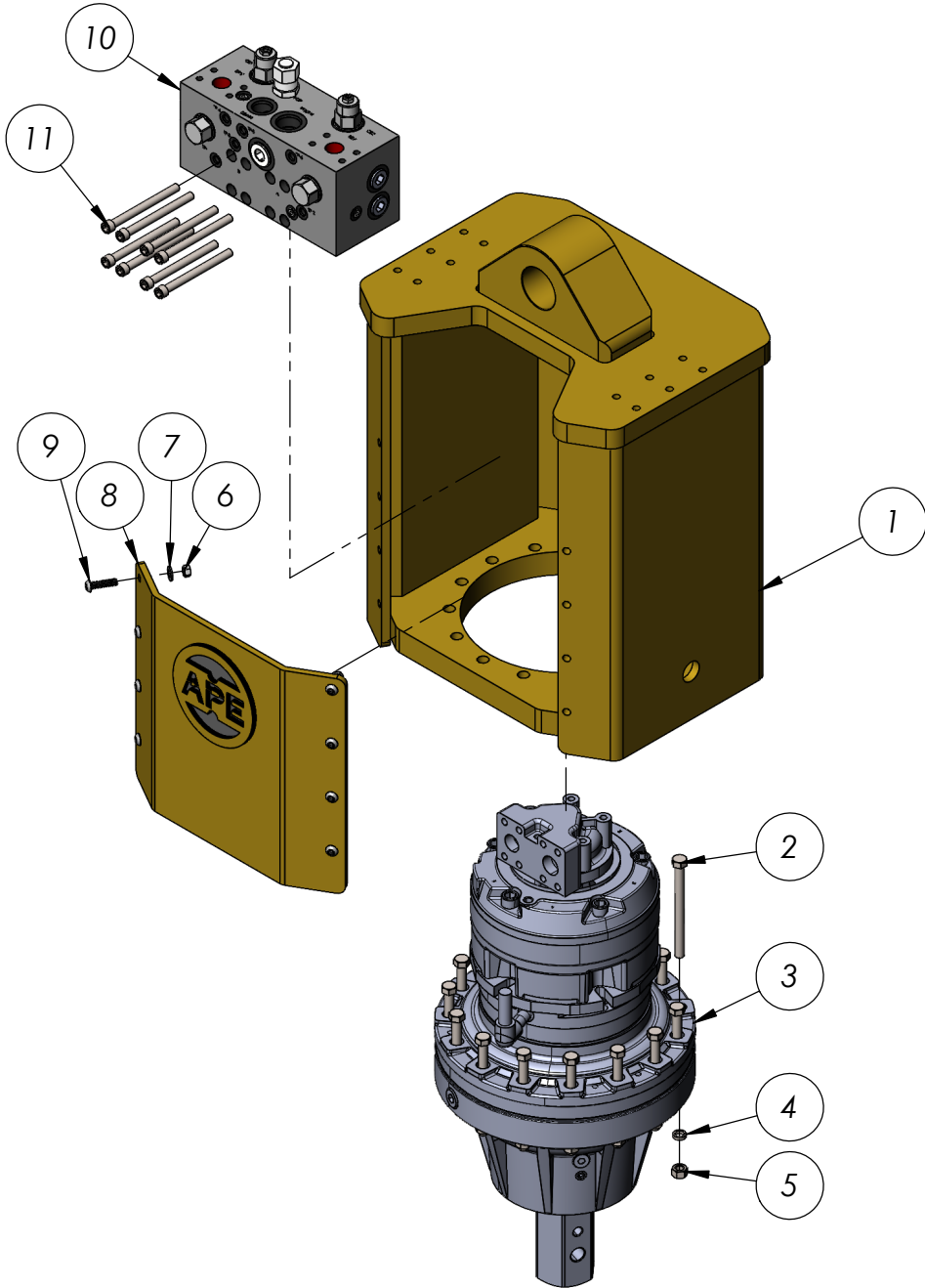

REPLACEMENT PARTS



REPLACEMENT PARTS

ITEM	QTY	PART NUMBER	DESCRIPTION	MANUFACTURER NUMBER
1	1	2005830	Drill Housing Machining	
2	15		HBOLT 1/2-13 X 6.00 X 1.25	
3	1	2005706-SN	* SAI Hydraulics FS30 Series hydraulic motor	FS30A1SA 175 9 12A D47RA DM2/PSR140 L2 H63-19-F2B
	1	2005707-SN	§ SAI Hydraulics FS50 Series hydraulic motor	FS50A1A 300 9 13 D47RA & PSR200 L2 H63-19-F32
4	15	100027	HCLW 1/2"	
5	15	100485	Hex Nut 1/2-13	
6	8	100535	Hi-Strength Hex Nuts 3/8-16	McMaster Carr 90499A031
7	8		3/8 Flat Washer	McMaster Carr 91083A031
8	1	2005831	SAI Dangle Drill Cover Plate	
9	8		BHHDS 3/8-16 X 1.5	91306A427
10	1	2005835	SAI Direct Mount Cushion lock ASM	
11	8	100626	SHCS 7/16-14 X 5.00 X 1.375	

NOTES:

- * Specific to 12K Dangle Drill
- § Specific to 20K Dangle Drill



REPLACEMENT PARTS

Dangle Drill Manifold

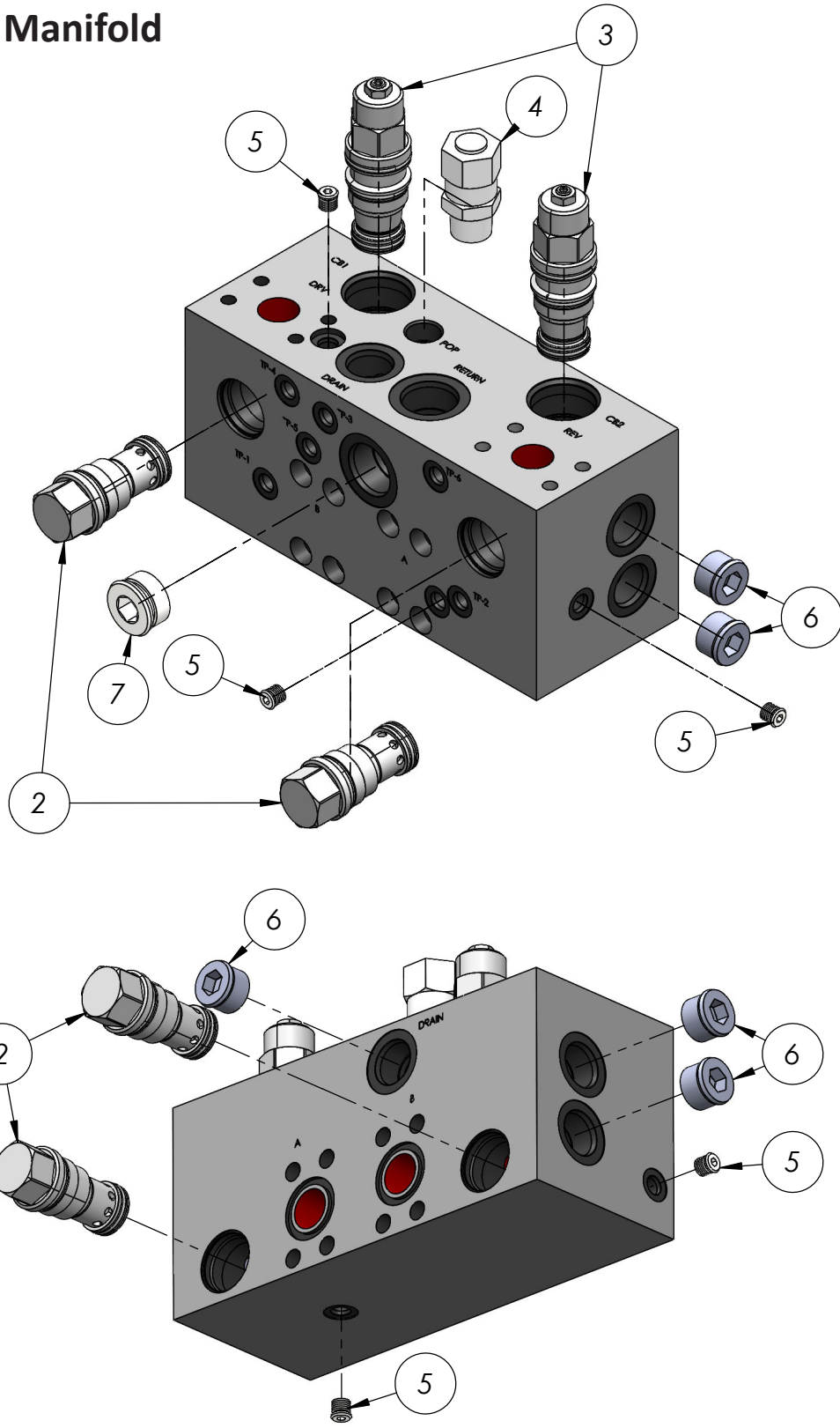

REPLACEMENT PARTS



REPLACEMENT PARTS

ITEM	QTY	PART NUMBER	DESCRIPTION	MANUFACTURER NUMBER
1	1	2005834	SAI Direct Mount Cushion lock Body	
2	4	352107	Check Valve	Sun CXHA-XAN
3	2		Piloted Counterbalance Valve	Sun CBGH-LDN
4	1	321009	Pop Off Valve	
5	5	600121	#4 SAE EPCO Plug	BRE6408-04-O
6	5	600125	#12 SAE EPCO Plug	BRE6408-12-O
7	1	600126	#16 SAE EPCO Plug	BRE6408-16-O



REPLACEMENT PARTS

Dangle Drill Accessories

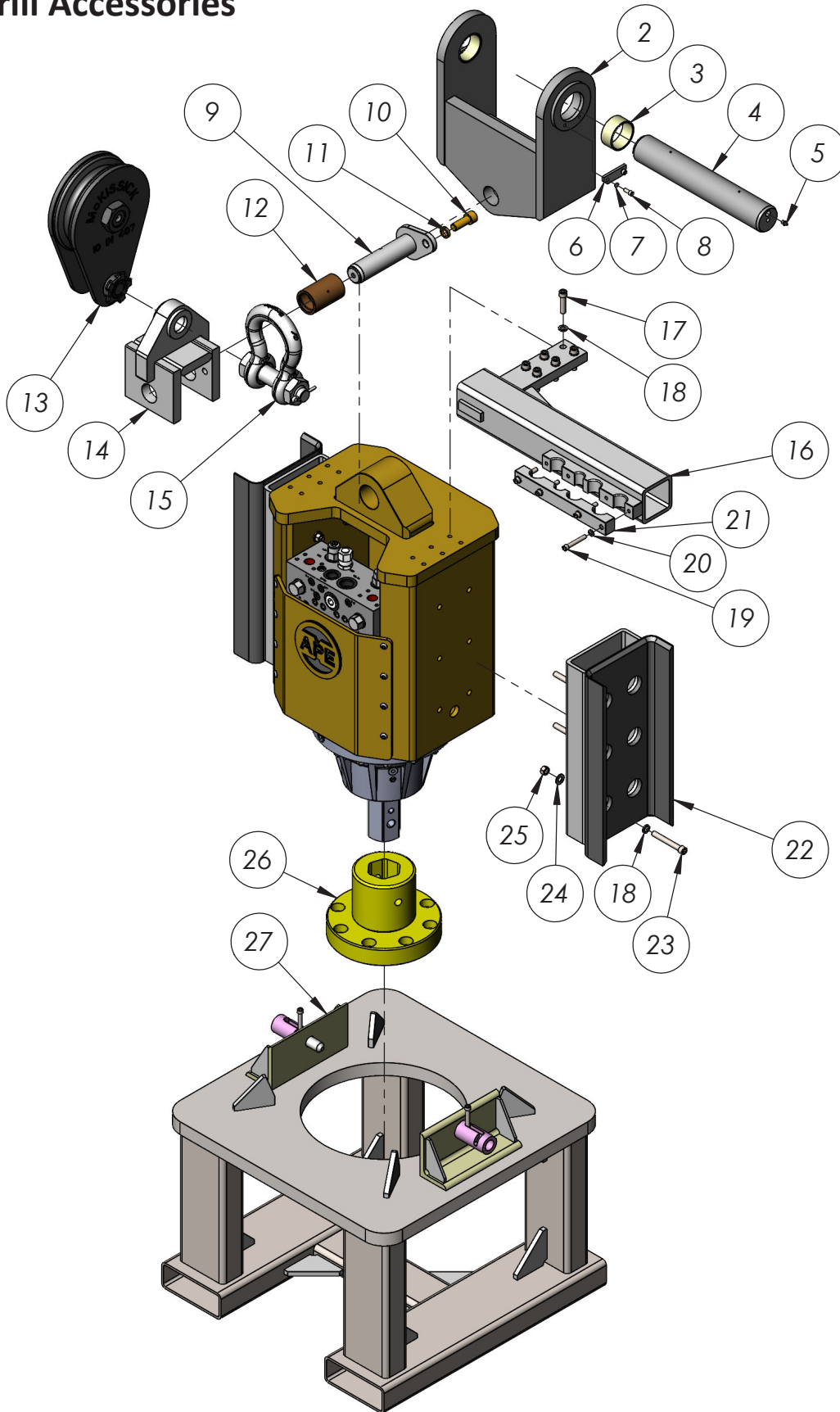

REPLACEMENT PARTS



REPLACEMENT PARTS

ITEM	QTY	PART NUMBER	DESCRIPTION	MANUFACTURER NUMBER
1	1	2007284	SAI Dangle Drill Top Level Assembly 12K	
	1	2007301	SAI Dangle Drill Top Level Assembly 20K	
2	1	2005828	Short Bale Machining	
3	2	2005848	Hardened Bushing	
4	1	2005844	Dangle Drill Bale Pin	
5	2	221001	1/8 NPT Grease Zerk	
6	2	1004538	Pin Retainer - Upper	
7	4	1003047	HCLW 5/16"	
8	4	1002973	SHCS 5/16-18 X 0.75	
9	1	2005840	SAI Dangle Drill Pin Assembly	
10	1	400069	SHCS 3/4-10 X 2.00	
11	1	1003057	HCLW 3/4"	
12	1	2005843	Alum Bronze Bushing	
13	1		McKissick 407 10in	
14	1	2007564	SAI Dangle Drill Adapter	
15	1		Crosby Shackle G-2130 1-1/2"	1019631
16	1	2007554	Dangle Drill Hose Chute Body	
17	6	100011	SHCS 1/2-13 X 2.00	
18	18	100121	Regular LW 1/2"	
19	4	1002986	SHCS 3/8-16 X 2.50 X 1.50	
20	4	400149	Regular LW 3/8"	
21	1	2007554-4	Dangle Drill Hose Chute Item 4	
22	2	2007523	Dangle Drill Lead Guides	
23	12		SHCS 1/2-13 X 3.75 X 1.50	
24	6		Preferred Narrow FW 1/2"	
25	6	100485	Hex Nut 1/2-13	
26	1	2007679	Hex Adapter	
27	1	2007272	SAI Drill Stand	

REPLACEMENT PARTS



REFERENCE / NOTES

UNDERSTANDING ISO CODES

The ISO cleanliness code is used to quantify particulate contamination levels per milliliter of fluid at 3 sizes 4μ[c], 6μ[c], and 14μ[c]. The ISO code is expressed in 3 numbers (ie 19/17/14). Each number represents a contaminant level code for the correlating particle size. The code includes all particles of the specified size and larger. It is important to note that each time a code increases the quantity range of particles is doubling.

ISO 4406 Chart		
Range Code	Particles per milliliter	
	More than	Up to/including
24	80000	160000
23	40000	80000
22	20000	40000
21	10000	20000
20	5000	10000
19	2500	5000
18	1300	2500
17	640	1300
16	320	640
15	160	320
14	80	160
13	40	80
12	20	40
11	10	20
10	5	10
9	2.5	5
8	1.3	2.5
7	0.64	1.3
6	0.32	0.64

Sample 1 (see photo 1)

Particle Size	Particles per ml*	ISO 4406 Code range	ISO Code
4μ[c]	151773	80000~160000	24
6μ[c]	38363	20000~40000	22
10μ[c]	8229		
14μ[c]	3339	2500~5000	19
21μ[c]	1048		
38μ[c]	112		

Sample 2 (see photo 2)

Particle Size	Particles per ml*	ISO 4406 Code range	ISO Code
4μ[c]	492	320 ~ 640	16
6μ[c]	149	80 ~ 160	14
10μ[c]	41		
14μ[c]	15	10 ~ 20	11
21μ[c]	5		
38μ[c]	1		

Photo 1

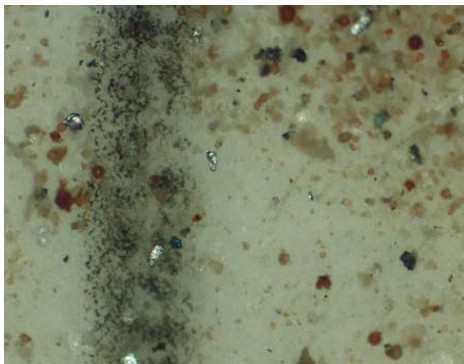

Photo 2



REFERENCE / NOTES

TARGET ISO CLEANLINESS CODES

When setting target ISO fluid cleanliness codes for hydraulic and lubrication systems it is important keep in mind the objectives to be achieved. Maximizing equipment reliability and safety, minimizing repair and replacement costs, extending useful fluid life, satisfying warranty requirements, and minimizing production down-time are attainable goals. Once a target ISO cleanliness code is set following a progression of steps to achieve that target, monitor it, and maintain it justifiable rewards will be yours.

Set the Target.

The first step in identifying a target ISO code for a system is to identify the most sensitive on an individual system, or the most sensitive component supplied by a central reservoir. If a central reservoir supplies several systems the overall cleanliness must be maintained, or the most sensitive component must be protected by filtration that cleans the fluid to the target before reaching that component.

Other Considerations

Table 1 recommends conservative target ISO cleanliness codes based on a several component manufacturers guidelines and extensive field studies for standard industrial operating conditions in systems using petroleum based fluids. If a non-petroleum based fluid is used (i.e. water glycol) the target ISO code should be set one value lower for each size (4 μ[c]/6μ[c]/14μ[c]). If a combination of the following conditions exists in the system the target ISO code should also be set one value lower:

- Component is critical to safety or overall system reliability.
- Frequent cold start.
- Excessive shock or vibration.
- Other Severe operation conditions.

Recommended* Target ISO Cleanliness Codes and media selection for systems using petroleum based fluids per ISO4406:1999 for particle sizes 4μ[c] / 6μ[c] / 14μ[c]

	Pressure	Media	Pressure	Media	Pressure	Media
	< 140 bar	βx[c] = 1000	212 bar	βx[c] = 1000	> 212 bar	βx[c] = 1000
	< 2000 psi	(βx = 200)	3000 psi	(βx = 200)	> 3000 psi	(βx = 200)
Pumps						
Fixed Gear	20/18/15	22μ[c] (25 μ)	19/17/15	12μ[c] (12 μ)	-	-
Fixed Piston	19/17/14	12μ[c] (12 μ)	18/16/13	12μ[c] (12 μ)	17/15/12	7μ[c] (6 μ)
Fixed Vane	20/18/15	22μ[c] (25 μ)	19/17/14	12μ[c] (12 μ)	18/16/13	12μ[c] (12 μ)
Variable Piston	18/16/13	7μ[c] (6 μ)	17/15/13	5μ[c] (3 μ)	16/14/12	7μ[c] (6 μ)
Variable Vane	18/16/13	7μ[c] (6 μ)	17/15/12	5μ[c] (3 μ)	-	-
Valves						
Cartridge	18/16/13	12μ[c] (12 μ)	17/15/12	7μ[c] (6 μ)	17/15/12	7μ[c] (6 μ)
Check Valve	20/18/15	22μ[c] (25 μ)	20/18/15	22μ[c] (25 μ)	19/17/14	12μ[c] (12 μ)
Directional (solenoid)	20/18/15	22μ[c] (25 μ)	19/17/14	12μ[c] (12 μ)	18/16/13	12μ[c] (12 μ)
Flow Control	19/17/14	12μ[c] (12 μ)	18/16/13	12μ[c] (12 μ)	18/16/13	12μ[c] (12 μ)
Pressure Control (modulating)	19/17/14	12μ[c] (12 μ)	18/16/13	12μ[c] (12 μ)	17/15/12	7μ[c] (6 μ)
Proportional Cartridge Valve	17/15/12	7μ[c] (6 μ)	17/15/12	7μ[c] (6 μ)	16/14/11	5μ[c] (3 μ)
Proportional Directional	17/15/12	7μ[c] (6 μ)	17/15/12	7μ[c] (6 μ)	16/14/11	5μ[c] (3 μ)
Proportional Flow Control	17/15/12	7μ[c] (6 μ)	17/15/12	7μ[c] (6 μ)	16/14/11	5μ[c] (3 μ)
Proportional Pressure Control	17/15/12	7μ[c] (6 μ)	17/15/12	7μ[c] (6 μ)	16/14/11	5μ[c] (3 μ)
Servo Valve	16/14/11	7μ[c] (6 μ)	16/14/11	5μ[c] (3 μ)	15/13/10	5μ[c] (3 μ)
Bearings						
Ball Bearing	15/13/10	5μ[c] (3 μ)	-	-	-	-
Gearbox (industrial)	17/16/13	12μ[c] (12 μ)	-	-	-	-
Journal Bearing (high speed)	17/15/12	7μ[c] (6 μ)	-	-	-	-
Journal Bearing (low speed)	17/15/12	7μ[c] (6 μ)	-	-	-	-
Roller Bearing	16/14/11	7μ[c] (6 μ)	-	-	-	-
Actuators						
Cylinders	17/15/12	7μ[c] (6 μ)	16/14/11	5μ[c] (3 μ)	15/13/10	5μ[c] (3 μ)
Vane Motors	20/18/15	22μ[c] (25 μ)	19/17/14	12μ[c] (12 μ)	18/16/13	12μ[c] (12 μ)
Axial Piston Motors	19/17/14	12μ[c] (12 μ)	18/16/13	12μ[c] (12 μ)	17/15/12	7μ[c] (6 μ)
Gear Motors	20/18/14	22μ[c] (25 μ)	19/17/13	12μ[c] (12 μ)	18/16/13	12μ[c] (12 μ)
Radial Piston Motors	20/18/15	22μ[c] (25 μ)	19/17/14	12μ[c] (12 μ)	18/16/13	12μ[c] (12 μ)
Test Stands, Hydrostatic						
Test Stands	15/13/10	5μ[c] (3 μ)	15/13/10	5μ[c] (3 μ)	15/13/10	5μ[c] (3 μ)
Hydrostatic Transmissions	17/15/13	7μ[c] (6 μ)	16/14/11	5μ[c] (3 μ)	16/14/11	5μ[c] (3 μ)

*Depending upon system volume and severity of operating conditions a combination of filters with varying degrees of filtration efficiency might be required (i.e. pressure, return, and off-line filters) to achieve and maintain the desired fluid cleanliness.

Example	ISO Code	Comments
Operating Pressure	156 bar, 2200 psi	
Most Sensitive Component	Directional Solenoid	19/17/14 recommended baseline ISO Code
Fluid Type	Water Glycol	18/16/13 Adjust down one class
Operating Conditions	Remote location, repair difficult High ingestion rate	17/15/12 Adjust down one class, combination of critical nature, severe conditions



REFERENCE / NOTES

Recommended Bolt Tightening Torque

When installing any APE equipment or parts apply lubricant and use APE standard **Anti-Seize** torque specs. See Tightening Torque Spec below. Failure to follow tightening torque spec can result in under / over tightening fasteners, leading to equipment failure or personal injury.



Socket Head Cap Screws

COARSE THREADS

Nominal Screw Size	Nominal Socket Size	Tightening Torque (ft-lbs)
#10-24	5/32	6
.25-20	3/16	10
.31-18	1/4	22
.38-16	5/16	38
.44-14	3/8	61
.50-13	3/8	93
.63-11	1/2	179
.75-10	5/8	317
.88-9	3/4	511
1.00-8	3/4	767
1.25-7	7/8	1,533
1.50-6	1	2,668

FINE THREADS

Nominal Screw Size	Nominal Socket Size	Tightening Torque (ft-lbs)
#10-32	5/32	6
.25-28	3/16	12
.31-24	1/4	24
.38-24	5/16	43
.44-20	3/8	68
.50-20	3/8	105
.63-18	1/2	202
.75-16	5/8	354
.88-14	3/4	564
1.00-12	3/4	860
1.25-12	7/8	1,697
1.50-12	1	3,001

RECOMMENDED ANTI-SEIZE LUBRICANT

BENEFITS & FEATURES

- Excellent Anti-Seize** Prevents seizing causing by galling, galvanic action, fretting, fusion, pitting, thread distortion, breakage, rust, and corrossions.
- Water Resistant** Provides long term protection with just one application, outdoors or indoors, even in the damp areas or against salt spray. Will not wash off.
- Wide Temperature Range** Coating withstands temperatures of -65 Degree F to 2100 Degree F. (-54 C to 1100 C)
- Stable Coating** Will not harden or fuse to metal, cake, evaporate or separate
- Compatible with many materials** Can be used as an anti-seize on the threads of steel, stainless steel, steel alloy, cast iron, aluminum, copper brass, and titanium parts and reduces friction and wear on plastic.
- Environmentally Desirable** Past contains no lead compounds traditionally found in this type of product.



WARNING: USING OTHER TYPES OF ANTI-SEIZE NOT RECOMMENDED BY APE CAN LEAD TO EQUIPMENT FAILURE OR PERSONAL INJURY. WARRANTY WILL BE VOIDED AND FEES MAY APPLY.



REFERENCE / NOTES

All information given in this Manual is current and valid per the information available at the time of publication. (Please check the updated revision date at the bottom of each page.)

American Piledriving Equipment (APE) reserves the right to implement changes without prior notice.

Please visit www.americanpiledriving.com for the most recent version of this publication.

AMERICAN PILEDRIVING EQUIPMENT, INC.

7032 S. 196th Street

Kent, Washington 98032

Office: 253-872-0141

Toll Free: 800-248-8498

Fax: 253-872-8710



800-248-8498

WWW.AMERICANPILEDRIVING.COM

MODEL 12K/20K DANGLE DRILL

Copyright © 2023 American Piledriving Equipment Inc. All Rights Reserved